

Service Bulletin

1 Subject:

14V ALT-FLX Alternator Installation

2 Applicability:

This Service Bulletin is applicable to the aircraft identified in Table 1.

Table 1 – Applicability

AIRCRAFT	SERIAL NUMBER(s)
GA8	This Service Bulletin is applicable to all GA8 aircraft. Written authorisation to install this optional service bulletin must be obtained from GippsAero before installation.
GA8-TC 320	This Service Bulletin is applicable to all GA8 TC 320 aircraft. Written authorisation to install this optional service bulletin must be obtained from GippsAero before installation.

3 Amendments:

Issue 1: Initial Issue

4 Background:

This Service Bulletin provides instructions for replacing the GippsAero GA8 Alternator and System Controller with the Hartzell Engine Technologies ALT-FLX Alternator and a R1224 Regulator. The aircraft alternator belt is also upgraded to a 4 or 5-groove serpentine belt.

5 Compliance:

The accomplishment instructions contained within this Service Bulletin are optional and may be incorporated at the Operator’s, Owner’s, or Maintenance Provider’s discretion only with the written permission of GippsAero.

6 Compatible equipment:

The installer must ensure this design change is compatible with configuration of the aircraft. Any installed equipment should be assessed for compatibility with this and co-requisite design changes. The engine must be equipped with a Skytec 149-12LS or 149-NL starter (or other approved starter which is equipped with the alternator brace mount point indicated in Figure 1).

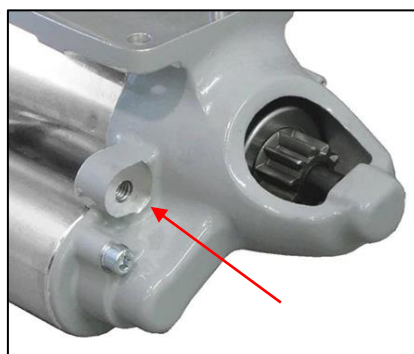

Figure 1 – Alternator Brace Mount Point

7 Weight and Balance:

The effect of this Service Bulletin's incorporation on the aircraft's weight and balance is shown below:

Table 2 – Equipment Removed

ITEM(S) REMOVED	WEIGHT		ARM		MOMENT	
	(kg)	(lb)	(mm)	(in)	(kg.mm)	(in.lb)
GippsAero Alternators: P/No. GA8-243011-015, GA8-243011-017 or GA8-243011-019	-5.0	-11.0	-975	-38.4	4875	422.4
Alternator Mount and Stay	-0.7	-1.5	-975	-38.4	683	57.6
Cooling Shroud	-0.1	-0.2	-383	-33.0	38.3	6.6
System Controller, P/No. GA8-243014-011	-0.2	-0.4	135	5.3	-27	-2.1

Table 3 – Equipment Installed

ITEM(S) INSTALLED	WEIGHT		ARM		MOMENT	
	(kg)	(lb)	(mm)	(in)	(kg.mm)	(in.lb)
ALT-FLX Alternator with Pulley	6.2	13.7	-975	-38.4	-6045	-526
Alternator Mount and Stay	0.5	1.1	-986	-38.8	-493	-42.7
R1224 Regulator	0.2	0.3	135	5.3	27	1.6

Table 4 – Net Weight and Balance Change

TOTAL	WEIGHT		ARM		MOMENT	
	(kg)	(lb)	(mm)	(in)	(kg.mm)	(in.lb)
14V ALT-FLX Alternator Installation	0.9	2.0	1047	41.4	-942	-82.7

The aircraft's weight and balance record shall be updated to include this information.

8 Electrical Load Analysis:

The effect of this Service Bulletin's incorporation on the aircraft's electrical load analysis is shown in Table 5. The aircraft's electrical load analysis shall be updated to include this information.

Table 5 – Electrical Load Analysis

COMPONENT	MAXIMUM CONTINUOUS @ 14V	CIRCUIT BREAKER LABEL	ELECTRICAL BUS	PHASES OF FLIGHT
Alternator data plate rating	100A	N/A	N/A	ALL

9 Approval:

The airframe and/or electrical system modification/repair described in this Service Bulletin has been approved pursuant to Australian Civil Aviation Safety Regulation 21.095 (1998). GippsAero Reference GAE11#2773.

10 Parts:

The following parts are required to accomplish this Service Bulletin.

Table 6 – Variant Installations

Variant	Application	Kit P/N
-1	GA8 Aircraft without a secondary 28V alternator installed (V-belt pulleys)	SB-GA8-2023-211-1
-2	GA8-TC320 Aircraft without a secondary 28V alternator or air-conditioning system installed (4-groove serpentine belts)	SB-GA8-2023-211-2
-3	Aircraft with a secondary 28V alternator or air-conditioner installed (5-groove serpentine belts)	SB-GA8-2023-211-3

Table 7 – Parts

ITEM	PART No.	DESCRIPTION	QTY		
			-1	-2	-3
1*	-	ALTERNATOR KIT			
1.1	17-2000-3	ALTERNATOR	1	1	1
1.2	10-1005C	PULLEY Ø3.5" Serpentine (4-groove)	1	1	
1.3	R1224	14V VOLTAGE REGULATOR	1	1	1
1.4	73383	LOCKPLATE 5/16 bolt x 1.00 spacing	1	1	1
1.5	10-1002	STARTER STRAP	1	1	1
2	GA-000421-021	ALTERNATOR PULLEY (5-groove)			1
3	GA8-242028-031	ALTERNATOR STAY	1	1	1
4	GA8-242028-033	ALT-FLX AIR TUBE STAY	1	1	1
5	GA8-242028-033	ALT-FLX ALTERNATOR BRACKET	1	1	1
6	GA-000444-025	BOLT, 5/16 UNC x 0.75	2	2	2
7	-	RESERVED			
8	GA8-212024-021	AIR OUTLET DUCT	1	1	1
9	HAS-016	HOSE CLAMP	1	1	1
10	GA8-710021-025	PENNY WASHER	1	1	1
11	AN7-43A	BOLT	1	1	1
12	AN960-716	WASHER	2	2	2
13	AN960-716L	THIN WASHER	2	2	2
14	AN960-516	WASHER	4	4	4
15	AN960-516L	THIN WASHER	4	4	4
16	LW-31-0-94	5/16-18X15/16 LONG BOLT	2	2	2
17	31M22993	SUPPORT ASSY STARTER RING GEAR (4-groove)	1		
18	4PK960	BELT	1		
	5PK1210	BELT		1	
19	MS21045-7	NUT, THIN	1	1	1

ITEM	PART No.	DESCRIPTION	QTY		
			-1	-2	-3
20	MS20074-5-06	BOLT	1	1	1
50	GA8-315021-033	SPACER	4	4	4
51	AN3-10A	BOLT	4	4	4
52	AN960-10	WASHER	4	4	4
53	MS21042-3	NUT	5	5	5
54	MS21042-4	NUT	1	1	1
55	MS25036-103	TERML LUG INSUL RING 22-18AWG #10 DIA RD	1	1	1
56	MS25036-148	TERML LUG INSUL RING 22-18AWG #4 DIA RD	3	3	3
57	MS25036-152	TERML LUG INSUL RING 16-14AWG #4 DIA BL	2	2	2
58	MS25036-154	TERML LUG INSUL RING 16-14AWG 1/4 DIA	1	1	1
59	M81824/1-3	SPLICE INSULATED AWG 16-12 YELLOW	1	1	1
61	MS25171-3S	NIPPLE ELECTRICAL TERMINAL D0.56 F0.43	1	1	1
62	2TC2-5	CIRCUIT BREAKER 5A	1	1	1

Table 8 – Compounds

ITEM	COMPOUND NUMBER	DESCRIPTION
C1	DURALAC	CHROMATE JOINTING COMPOUND
C2	LOCTITE 272	THREADLOCKER
C3	LOCTITE 7471	ACTIVATOR / PRIMER

11 Parts Availability:

New parts can be obtained directly from GippsAero.

Tel: +61 (0)3 5172 1200

Fax: +61 (0)3 5172 1201

Email: PARTS@gippsaero.com.au

12 Labour:

12 man hours should be allocated for completing the work detailed in this Service Bulletin. This time does not include set up etc.

13 Warranty:

This is an optional modification. The cost of installation is not eligible for warranty claims, however, component warranties are provided by the respective manufacturers.

Tel: +61 (0)3 5172 1200

Fax: +61 (0)3 5172 1201

Email: SUPPORT@gippsaero.com.au

14 Accomplishment Instructions:

WARNING:

IT IS THE RESPONSIBILITY OF ALL PERSONNEL TO ENSURE WORK HEALTH AND SAFETY REQUIREMENTS ARE MET AT ALL TIMES. ALL PERSONNEL MUST COMPLY WITH ALL WORK HEALTH AND SAFETY REQUIREMENTS AS DEFINED OR RECOMMENDED BY:

- EQUIPMENT OEM INSTALLATION AND OPERATION MANUALS;
- AIRCRAFT MAINTENANCE AND OPERATION MANUALS;
- ASSOCIATED AIRCRAFT MODIFICATION INSTRUCTIONS;
- RELEVANT NAA REGULATIONS AND ADVISORY DOCUMENTATION;
- ORGANISATION MANUALS, INCLUDING NAA ENDORSED OPERATIONAL AND MAINTENANCE MANUALS; AND
- RELEVANT LOCAL, STATE AND FEDERAL GOVERNMENT REQUIREMENTS.

WARNING:

READ THE APPLICABLE MATERIAL SAFETY DATA SHEET (MSDS) FOR ANY MATERIAL/CONSUMABLE USED DURING THE ACCOMPLISHMENT OF THIS SERVICE BULLETIN AND EMPLOY ANY RECOMMENDED PERSONAL PROTECTIVE EQUIPMENT (PPE) CONTAINED THEREIN.

NOTE:

Unless otherwise specified, reference to the GA8/GA8-TC 320 Service Manual and FAA Advisory Circular (AC) 43.13-1B should be made when carrying out the procedures prescribed in this Service Bulletin. In case of a discrepancy between the Service Manual and the AC, the Service Manual takes precedence.

Torque all fasteners in accordance with the GA8 or GA8-TC 320 Service Manual or Lycoming Engine ICA unless stated otherwise. Values are for dry (unlubricated) threads unless shown otherwise.

Apply all compounds in accordance with manufacturer's instructions. Clean mating parts thoroughly using solvent compound C5 (Table 8) before assembly.

All work specified in this Service Bulletin shall be carried out by appropriately qualified personnel.

Unless stated otherwise, hardware removed during the procedure below is to be inspected and re-used if serviceable.

14.1 PART A – ALTERNATOR INSTALLATION

14.1.1 Initial Preparation

1. Read these instructions fully before commencing any work.
2. Ensure you have noted the variant applicable to your aircraft. In case of discrepancies contact GippsAero for advice.
3. It is the installers responsibility to check that the installation as described by this Service Bulletin is (i) compatible with the existing aircraft configuration and (ii) that other modifications intended to be carried out at the same time are compatible with this Service Bulletin and do not occupy the same physical location on the aircraft.
4. Ensure the aircraft is safe for maintenance.
5. Inspect the alternator (Item 1.1) to ensure that the output terminal is located correctly per Figure 2.
6. Remove the 12V battery in accordance with the GA8 or GA8-TC 320 Service Manual.

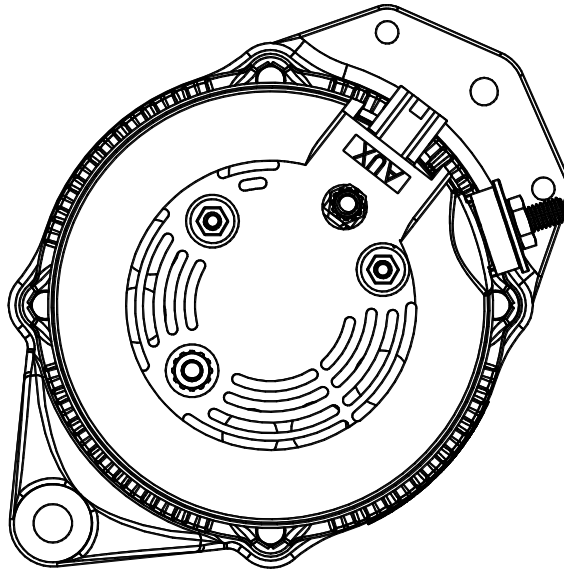

Figure 2 – Alternator Orientation (view looking at rear of alternator)

7. Remove the engine cowls.
8. Remove the GippsAero Alternator (P/N GA8-243011-015, GA8-243011-017 or GA8-243011-019), cooling shroud (P/N GA8-242027-011), air outlet duct (GA8-212024-021) and discard.
9. Remove the alternator mounting bracket (P/N GA200-242317-001) & alternator stay (P/N GA8-242028-021) and discard along with attachment hardware.

14.1.2 Variant -1 Ring Gear Replacement

10. Remove the propeller in accordance with the Hartzell Propeller Owner's Manual at latest revision.
11. Remove the existing starter ring gear support assembly and alternator belt from the aircraft engine and discard.
12. Install the multi groove ring gear (Item 15) and the appropriate alternator belt (Item 16).
13. Refit the propeller in accordance with the Hartzell Propeller Owner's Manual at latest revision.

14.1.3 Variant -3 Alternator Pulley Replacement

14. Remove the pulley wheel from the alternator (Item 1.2) and discard. Retain the lock washer and nut.
15. Apply anti-corrosive compound C1 (Table 8) at the interfaces of the Alternator Pulley and the Alternator shaft and fit the Alternator Pulley (Item 2). Apply Thread Locker Compound C2 (Table 8) to the thread, fit the lock washer and nut and torque the nut to 55 ft.lb.

NOTE:

Primer/activator compound C3 (Table 8) is recommended where rapid cure is preferred.

14.1.4 All Variants – Mechanical Installation of Alternator

16. Install the alternator as detailed in Figure 3 to Figure 6.

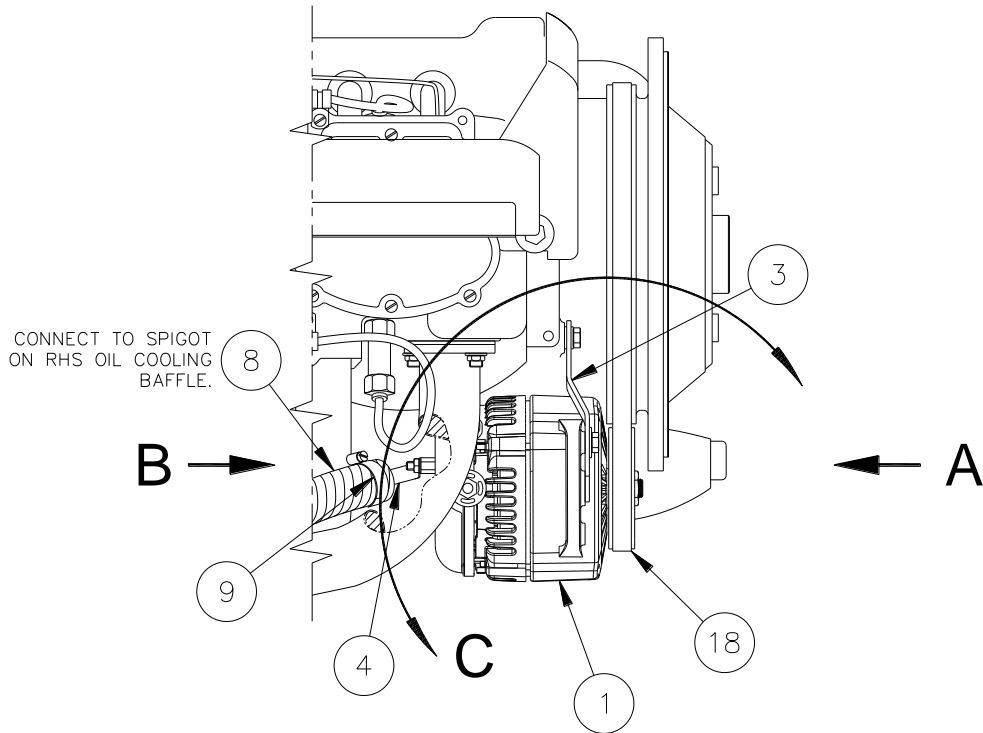
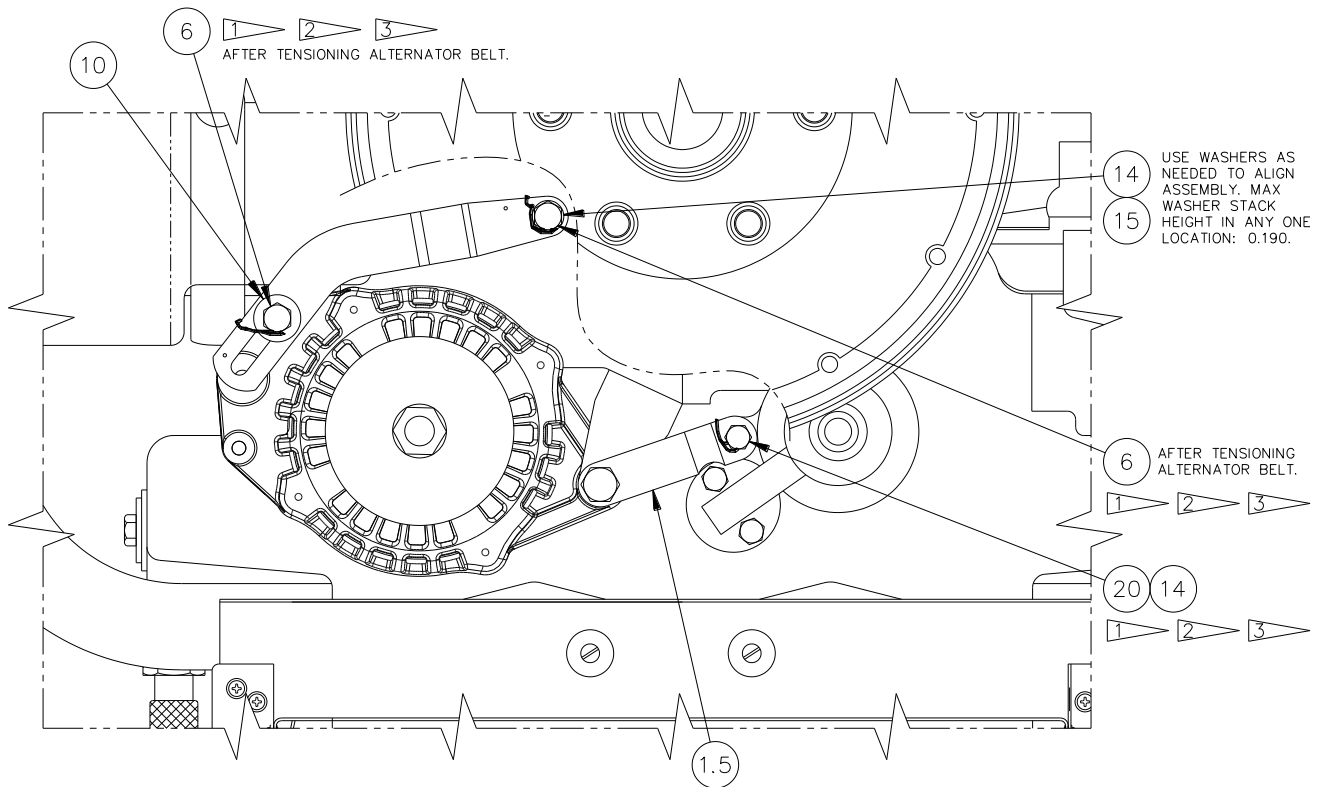

Figure 3 – Alternator Installation



DETAIL VIEW A
VIEW LOOKING AFT AT ALTERNATOR INSTALLATION

- 1 UNLESS OTHERWISE SPECIFIED, ALL HARDWARE IS TO BE INSTALLED IN ACCORDANCE WITH THE APPLICABLE AIRCRAFT SERVICE MANUAL.
- 2 INDICATED HARDWARE ARE TO BE SAFETY LOCKED USING LOCK WIRE IN ACCORDANCE WITH FAA AC 43.13-1B
- 3 TORQUE TO 204 in.lb

Figure 4 – Alternator Detail View A

FIX TO INBOARD STUD.
 BEND ANGLE OF ITEM 525 MAY BE ADJUSTED
 AS REQUIRED TO GIVE BEST PATH FOR AIR HOSE.
 HOLD THE POST WITH A WRENCH
 AND TORQUE NUT TO 20 - 35 lb.in.

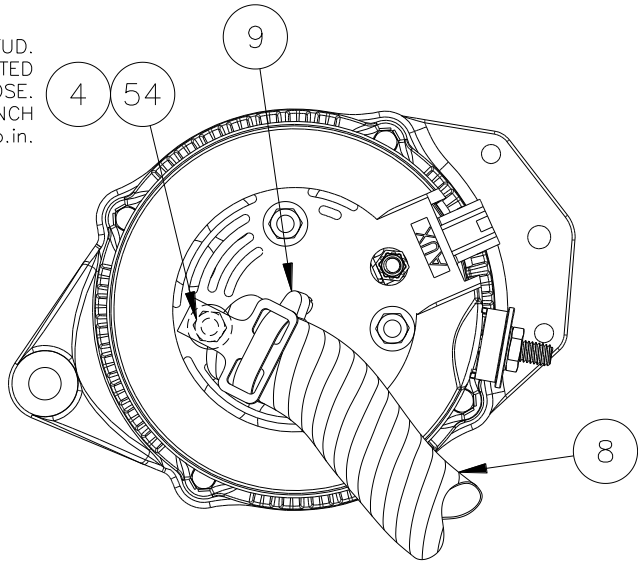

DETAIL VIEW B

ALTERNATOR AIR TUBE INSTALLATION
 SEVERAL PARTS NOT SHOWN FOR CLARITY

Figure 5 – Alternator Detail View B

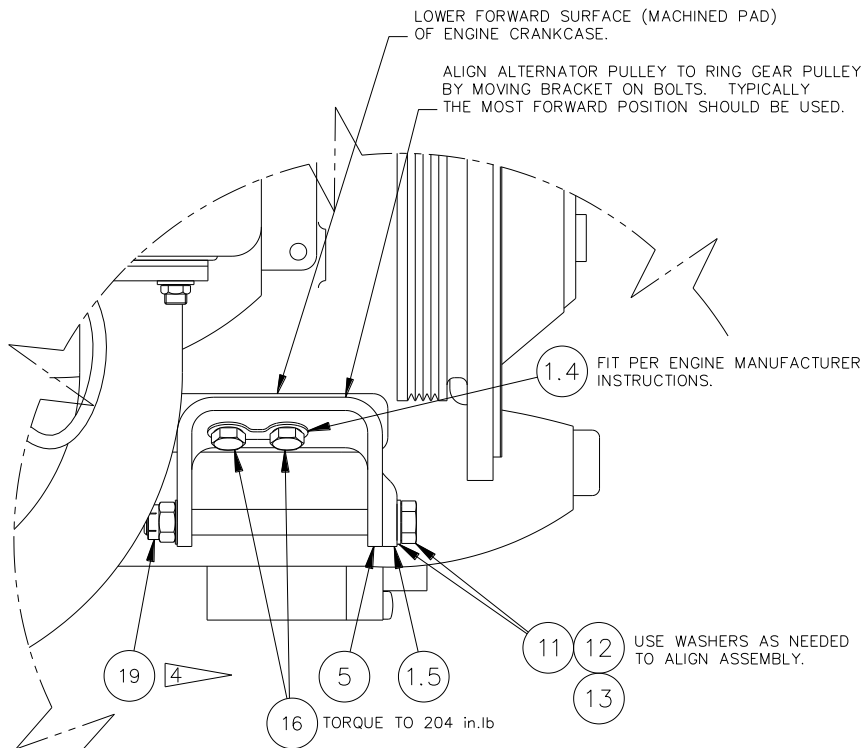

DETAIL VIEW C

SIDE VIEW OF BRACKET INSTALLATION
 ALTERNATOR AND STAY NOT SHOWN FOR CLARITY

4 TORQUE TO 270 in.lb

Figure 6 – Alternator Detail View C

14.1.5 Under Floor Circuit Breaker Panel Assy

17. Refer GA8 / GA8-TC 320 Maintenance Manual and remove the Under Floor Circuit Breaker Panel Assy.
18. Remove the Alternator Field, 10A circuit breaker and discard.
19. Install 5A Circuit Breaker (item 62), and reconnect wiring.
20. Refit the Under Floor Circuit Breaker Panel Assy.

14.1.6 Voltage Regulator Installation

21. Disconnect the wiring from the System Controller.
22. Remove the Caution Unit Tray Assembly.
23. Remove the System Controller from the Caution Unit Tray Assembly.

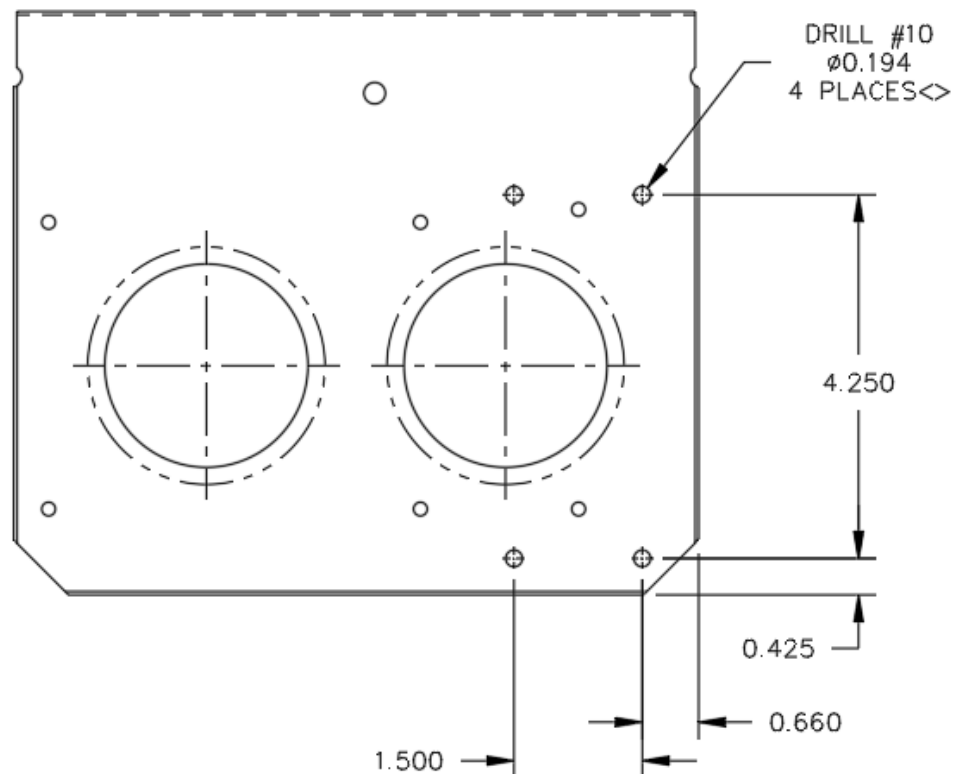

Figure 7 – Caution Unit Tray Assembly

24. Mark off 4 mounting holes in the Caution Unit Tray Assembly as shown in Figure 7. Ensure the mounting holes will allow the fasteners to be clear of the underlying structure then the Caution Unit Tray Assembly is refitted and adjust the position if required.
25. Drill 4 x #10 mounting holes in the Caution Unit Tray Assembly, deburr and restore finish.

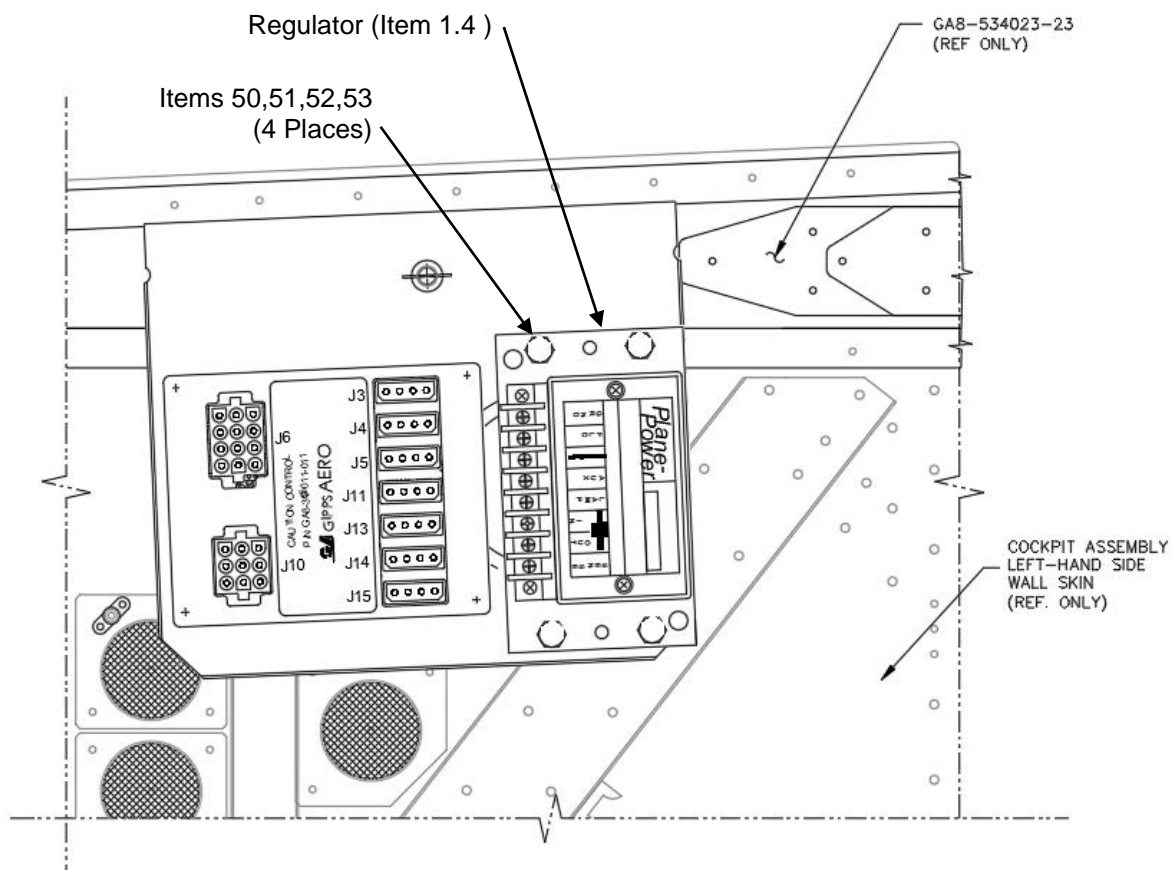

Figure 8 – Regulator Installation

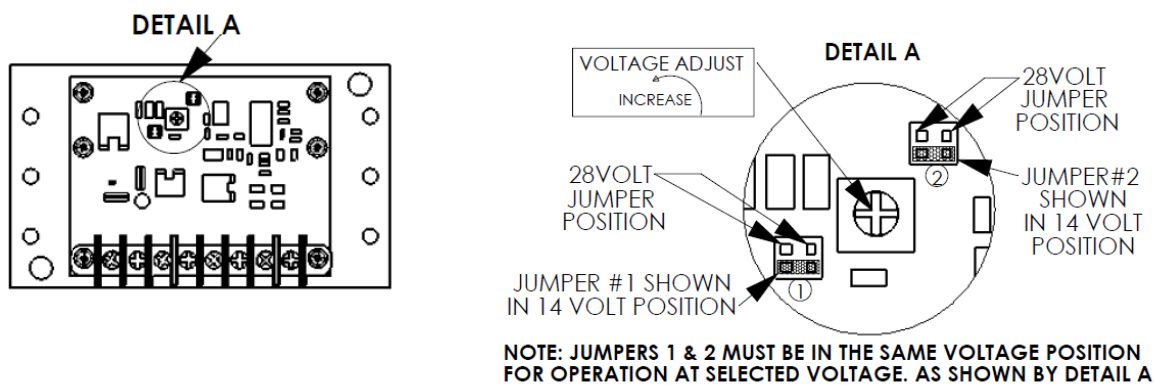

Figure 9 – Voltage Regulator Voltage setting check

26. Remove the regulator cover and ensure that the internal jumper #1 and jumper #2 are set for 14V. Refer Figure 9.

CAUTION:

FAILURE TO CORRECTLY CONFIGURE THE R1224 REGULATOR WILL DAMAGE ELECTRICAL SYSTEMS NOT DESIGNED TO OPERATE AT 28V.

27. Install the R1224 Voltage Regulator, using 4 x bolts, washers, spacers, and nuts (Items 50,51,52,53) to the Caution Unit Tray Assembly
28. Reinstall the Caution Unit Tray Assembly. Reconnect all disturbed electrical connectors on the Caution Controller.

14.1.7 Electrical Wiring.

29. Install wire PG19A18 (AUX wire) between the Caution controller mounting tray and the alternator. Tie the wire into the main loom. Install terminals and connect to the Alternator and regulator (Ref Figure 10).
30. Connect the wire PG2E14 to the ALT-FLX supplied 15-5050 Wire Harness/Plug wire F1 using an environmental splice (item 59). Connect the F2 wire to an earth stud on the alternator using terminal item 58.
31. Fit an insulating nipple (item 60) to the main power lead PG1A6 and connect to the alternator B+ stud.
32. Refer Figure 10, using appropriate terminals, connect the wiring to the R1224 Voltage Regulator.
33. Measure the electrical resistance from the negative terminal of the alternator to the earth pin of the 14V ground power connector. Resistance shall be less than 2 milli ohms.
34. Measure the electrical resistance between terminal 1 of the regulator to the earth pin of the 14V ground power connector. Resistance shall be less than 0.1 ohm.

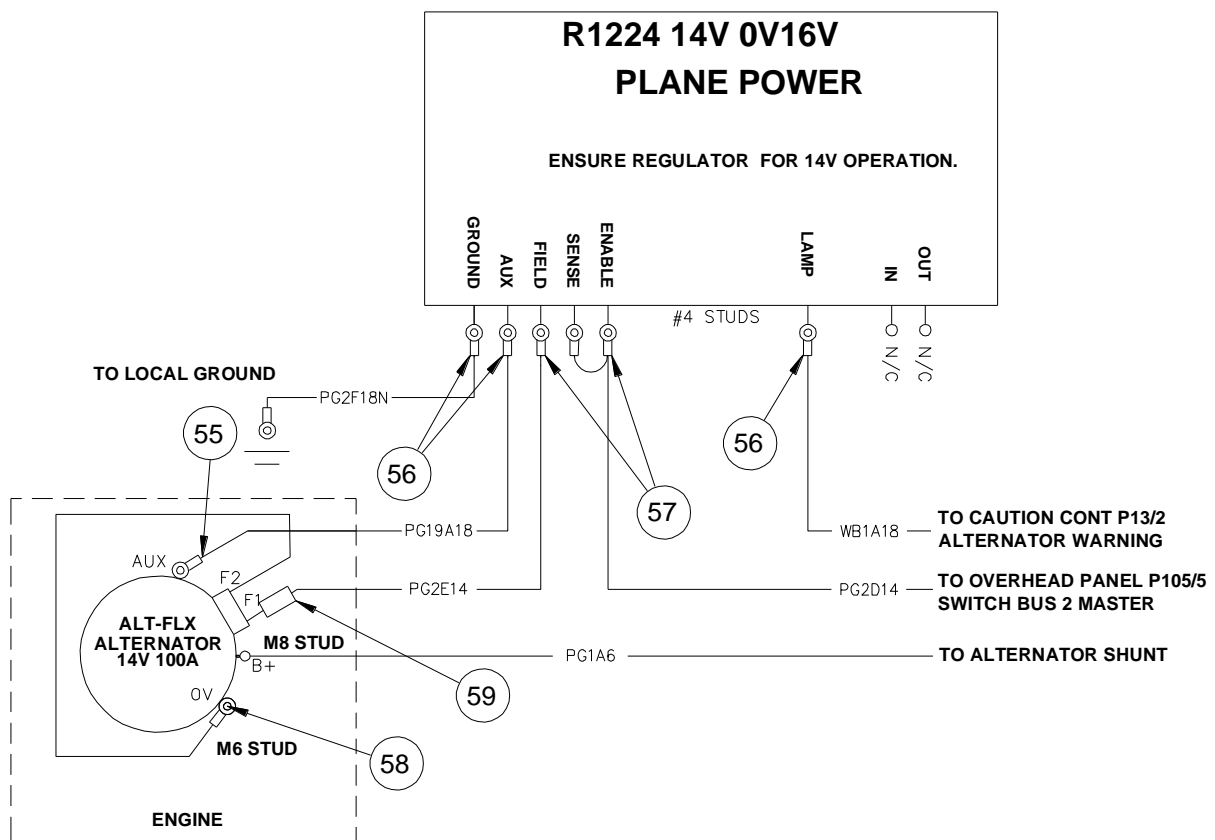

Figure 10 – Wiring Diagram

14.1.8 Restoration and Re-Assembly

35. Connect the aircraft's 12V battery in accordance with the GA8 or GA8-TC 320 Service Manual.
36. Fit the lower engine cowl in accordance with the GA8 or GA8-TC 320 Service Manual.
37. Check for clearance between the alternator and the lower cowl.
38. Refit the upper cowl.

14.2 PART B – TESTING

39. Perform a functional test of the warning light system.

Regulator Voltage Adjustment

40. For general service the regulator can be set to 14.0 to 14.25V. Battery service life can be prolonged by compensating the charging voltage based on the battery temperature. Refer RG® Series Aircraft Battery Owner/Operator Manual for further detail.

Table 9 – Recommended Voltage Regulator Settings

Battery Temperature	Voltage Regulator Setting (Volts DC)
Below 0°C (32°F)	14.5 – 14.75
0 to 15°C (32 to 59°F)	14.25 – 14.5
16 to 30°C (60 to 86°F) (default)	14.0 – 14.25
31 to 45°C (87 to 113°F)	13.75 – 14.0

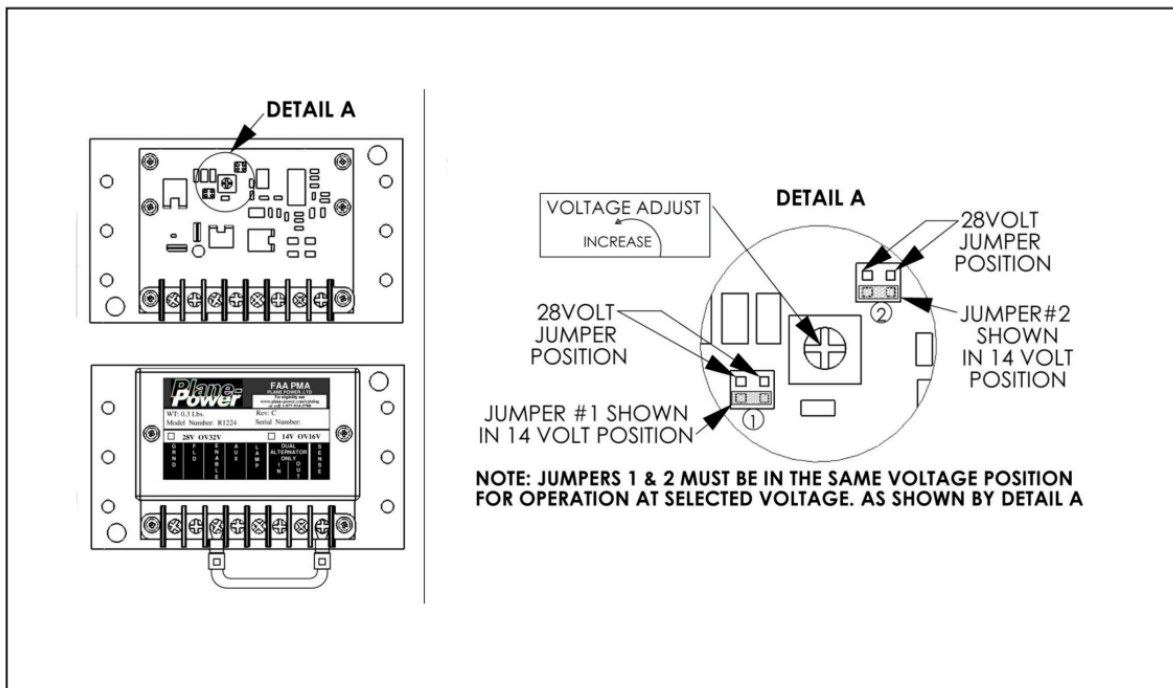

Figure 11 Regulator Voltage Adjustment

41. Remove the regulator cover and ensure that the internal jumper #1 and jumper #2 are set to the 14V jumper settings. Refer to Figure 11

CAUTION:

FAILURE TO CORRECTLY CONFIGURE THE R1224 REGULATOR WILL DAMAGE ELECTRICAL SYSTEMS NOT DESIGNED TO OPERATE AT 28V.

42. Refer Table 9. With the engine running and the alternator switch turned on, using a small screwdriver, set the regulator's voltage adjustment so that the bus voltage, as measured at the ENABLE terminal is the desired value.

43. Reinstall the regulator cover.

15 Documentation:

Update aircraft logbook to reflect incorporation of this Service Bulletin.

Insert Service Manual Supplement, C05-96-93 14V ALT-FLX Alternator, Initial Issue (or later approved issue) into the aircraft's Service Manual.

16 Continuing Airworthiness:

Instructions for Continued Airworthiness are contained in service manual supplement C05-96-93

17 Compliance Notice:

Complete the Document Compliance Notice and return to GippsAero by mail, fax or email.

DOCUMENT COMPLIANCE NOTICE



Document:

SB-GA8-2023-211

Issue 1

Aircraft Serial Number: GA8-_____

Service Bulletin SB-GA8-2023-211, Issue 1 has been incorporated in the above aircraft.

Date of Incorporation: _____

Signed

Print Name: _____

If this Service Bulletin requires any inspections be carried out, describe the result of these inspections:

Please post, fax or email this compliance notice to:

GippsAero Technical Services
P.O. Box 881
Morwell Victoria 3840
Australia
Fax.: +61 03 5172 1201
Email: TECHPUBS@gippsaero.com.au