



PO Box 881, Morwell, Victoria 3840, Australia
Ph + 61 (0) 3 5172 1200
Fax + 61 (0) 3 5172 1201
www.gippsaero.com.au

SB-GA8-2025-220

Issue 2

OPTIONAL

Service Bulletin

1 Subject:

Dual Damped Nose Leg Installation.

2 Applicability:

This Service Bulletin is applicable to the aircraft identified in Table 1.

Table 1: Applicability

AIRCRAFT	SERIAL NUMBER(s)
GA8	This Service Bulletin is applicable to all GA8 aircraft.
GA8-TC 320	This Service Bulletin is applicable to all GA8 TC 320 aircraft.

3 Amendments:

Table 2: Issue Status

ISSUE	DESCRIPTION	REF.	DATE
1	Initial issue.	GAE11-2524	13 Mar 2025
2	BOM updated. Detail and formatting updates.	GAE11-2856	27 Jun 2025

4 Background:

This Service Bulletin provides instructions to upgrade the aircraft's existing Nose Gear Assembly (P/No. GA8-322011-011) to a new configuration, using different springs and a dual-rate damping system. The revised leg assembly uses a different part number, as shown in Figure 1.

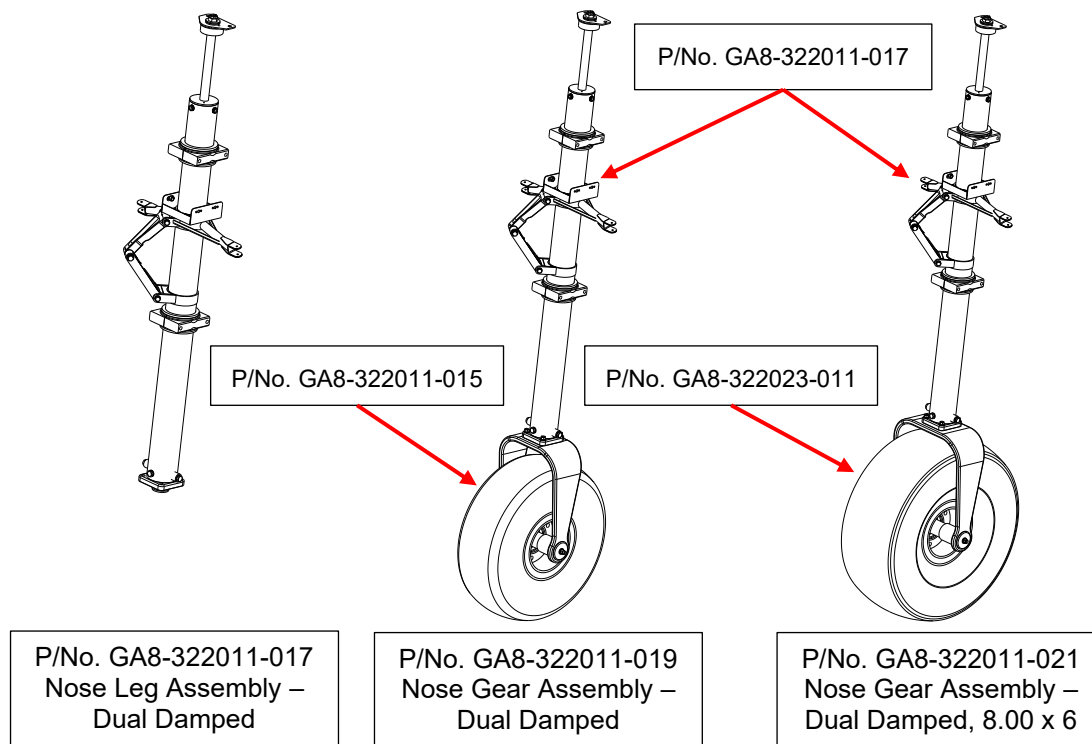

Figure 1: Leg Configurations

5 Compliance:

The accomplishment instructions contained within this Service Bulletin are optional and may be incorporated at the Operator's, Owner's or Maintenance Provider's discretion.

This modification is compatible with the GippsAero options listed in Table 3. Compatibility with other modifications must be verified by the aircraft owner and maintenance controller before installation.

Table 3: Compatible Options

AIRCRAFT	OPTION	DESCRIPTION
GA8 and GA8-TC 320	SB-GA8-2006-33	Installation of 8.00 x 6 Nose Wheel
GA8-TC 320	SB-GA8-2011-65	Increased Gross Weight Modifications (both Part A and Part B)
GA8	SB-GA8-2011-66	Increased Gross Weight Modifications (both Part A and Part B)

6 Weight and Balance:

The effect of this Service Bulletin's incorporation on the aircraft's weight and balance is shown in Table 4.

Table 4: Weight and Balance

TOTAL	WEIGHT		ARM		MOMENT	
	(kg)	(lb)	(mm)	(in)	(kg.mm)	(in.mm)
Dual Damped VS Equivalent Single-Damped Assembly	1.45	3.20	-158.8	-6.25	-230.4	-20.0

The aircraft's weight and balance record shall be updated to include this information.

7 Electrical Load Analysis (ELA):

This Service Bulletin has no effect on the aircraft's ELA.

8 Approval:

The airframe modification described in this Service Bulletin has been approved pursuant to Australian Civil Aviation Safety Regulation 21.095 (1998).

9 Parts:

The following parts are required to accomplish this Service Bulletin.

Table 5: Required Parts

ITEM	PART No.	DESCRIPTION	QTY	REMARKS
1	GA8-322021-163	NOSE LEG SPRING – OUTER	1	-
2	GA8-322021-165	NOSE LEG SPRING – INNER	1	-
3	GA8-322021-167	PISTON ROD PLUNGER, 2 SPRING	1	-
4	GA8-322021-169	NLG DAMPER SLEEVE	1	-
5	GA8-322021-171	TOP CAP – DUAL DAMPED	1	-
6	GA8-322021-009	PISTON ROD ASSY – DUAL DAMPED	1	-
11	418G00007	Roll Pin	2	-
12	MS28775-328	O-Ring - Plunger	1	-
13	MS28775-226	O-Ring – Top Cap External	1	-
14	MS28775-116	O-Rings – Top Cap Internal	2	-
15	NAS601-6	Screw	4	-
16	AN932-2D	Plug	2	-
17	AN960-416	Washer	4	-
18	NAS6204-6	Bolt	4	-

Table 6: Compounds List

ITEM	COMPOUND NUMBER	DESCRIPTION
C1	LOCTITE® 243	Medium Strength Thread Locker
C2	LOCTITE® 7471	Activator / Primer
C3	MIL-H-5606	Hydraulic Fluid
C4	MEK ACETONE PREPSOL	SOLVENTS

10 Parts Availability:

New parts can be obtained directly from GippsAero.

Tel: +61 (0)3 5172 1200

Fax: +61 (0)3 5172 1201

Email: PARTS@gippsaero.com.au

11 Labour:

12 man hours should be allocated for completing the work detailed in this Service Bulletin. This time does not include set up etc.

12 Warranty:

This is an optional modification. Installation warranty is not applicable, however component warranties are provided.

13 Accomplishment Instructions:

13.1 General

WARNING:

IT IS THE RESPONSIBILITY OF ALL PERSONNEL TO ENSURE WORK HEALTH AND SAFETY REQUIREMENTS ARE MET AT ALL TIMES. ALL PERSONNEL MUST COMPLY WITH ALL WORK HEALTH AND SAFETY REQUIREMENTS AS DEFINED OR RECOMMENDED BY:

- **EQUIPMENT OEM INSTALLATION AND OPERATION MANUALS;**
- **AIRCRAFT MAINTENANCE AND OPERATION MANUALS;**
- **ASSOCIATED AIRCRAFT MODIFICATION INSTRUCTIONS;**
- **RELEVANT NAA REGULATIONS AND ADVISORY DOCUMENTATION;**
- **ORGANISATION MANUALS, INCLUDING NAA ENDORSED OPERATIONAL AND MAINTENANCE MANUALS; AND**
- **RELEVANT LOCAL, STATE AND FEDERAL GOVERNMENT REQUIREMENTS.**

WARNING:

READ THE APPLICABLE MATERIAL SAFETY DATA SHEET (MSDS) FOR ANY MATERIAL/CONSUMABLE USED DURING THE ACCOMPLISHMENT OF THIS SERVICE BULLETIN AND EMPLOY ANY RECOMMENDED PERSONAL PROTECTIVE EQUIPMENT (PPE) CONTAINED THEREIN.

WARNING:

ALL WORK SPECIFIED IN THIS SERVICE BULLETIN SHALL BE CARRIED OUT BY APPROPRIATELY QUALIFIED PERSONNEL

NOTE:

Read all the applicable instructions prior to initiating any work.

The installer must ensure this design change is compatible with configuration of the aircraft. Contact GippsAero Engineering for further guidance if the instructions of this Bulletin are unsuitable for a particular aircraft configuration or do not achieve the required outcomes.

Ensure the aircraft is prepared for maintenance and that appropriate safety precautions are taken when performing work outlined in this Service Bulletin.

Unless otherwise specified, reference to the GA8/GA8-TC 320 Service Manual and FAA Advisory Circular (AC) 43.13-1B should be made when carrying out the procedures prescribed in this Service Bulletin. In case of a discrepancy between the Service Manual and the AC, the Service Manual takes precedence.

When carrying out work outlined by this Service Bulletin, care is to be taken to ensure damage to surrounding structure and installations does not occur.

Unless stated otherwise, hardware removed during the procedure below is to be inspected and re-used if serviceable.

13.2 Part A – Nose Leg Modification

1. Remove the nose landing gear from the aircraft in accordance with the applicable Aircraft Service Manual.
2. Remove the original Upper Bearing Carrier Assembly (P/No. GA8-322021-019) and Upper Nut Assembly (P/No. GA8-322021-127). Inspect the parts, clean and prepare for re-use.
3. Remove one of the tapered filler plugs from the upper nose leg cap. Drain and discard the hydraulic fluid.
4. Remove and discard the 4 bolts and washers holding the top cap of the leg into the nose leg assembly (for aircraft up to S/No. 50, QTY 3 AN4 bolts are used at this location).
5. Remove the main spring, the upper shaft and plunger from the leg assembly.

6. Remove the roll pin from the shaft and un-screw the plunger. Discard the old roll pin.
7. Remove and discard the original Plunger (P/No. GA8-322021-037) Piston Rod Assembly (P/No. GA8-322021-023) and Top Cap (P/No. GA8-322021-139). These parts will not be used in the revised leg assembly.
8. Fit the internal and external O-Rings (Items 13 and 14) to the new Top Cap (Item 5).
9. Using a Piston Rod Assembly – Dual Damped (Item 6), begin to re-assemble the leg.
10. Lubricate the Piston Rod Assembly (Item 6) with hydraulic fluid (C3 of Table 6) and fit to the Top Cap (Item 5) and Damper Sleeve (Item 4) as shown in Figure 2.
11. Clean the Screws (Item 15) and the corresponding threaded holes in the underside of the Top Cap (Item 5) using a suitable nil-residue cleaner (C4 of Table 6).
12. Apply a small amount of thread locker (C1 of Table 6) to the Screws (Item 15) and attach the Damper Sleeve (Item 4) to the Top Cap (Item 5) as shown in Figure 2. If a faster cure is required, activator/primer (C2 of Table 6) may be used; refer to manufacturer's data for use.
13. Re-fit the existing rebound spring, P/No. GA8-322021-143.
14. Fit the Plunger (Item 3) to the Piston Rod Assembly (Item 6) as shown in Figure 3.
15. Using the Piston Rod Assembly (Item 6) as a guide, drill the plunger (Item 3) for the installation of the roll pin as shown in Figure 3.
16. Clean and dry the part thoroughly to remove all drilling residue.
17. Fit the new Roll Pin (Item 11).
18. Install the new springs (Items 1 and 2) to the leg.
19. Lubricate the O-Rings of the Plunger (Item 3) and Top Cap (Item 5) with hydraulic fluid (C3 of Table 6) and fit to the leg.
20. Clean the Bolts (Item 18) and the corresponding threaded holes in the Top Cap (Item 5) using a suitable nil-residue cleaner (C4 of Table 6).
21. Apply a small amount of thread locker (C1 of Table 6) to the Bolts (Item 18) and Install the four Bolts (Item 18) and washers (Item 17) to the Top Cap (Item 5) as shown in Figure 4. Torque to 110 lb.in. If a faster cure is required, activator/primer (C2 of Table 6) may be used; refer to manufacturer's data for use.
22. Fill the leg with hydraulic fluid (C3 of Table 6) to the top of the Top Cap (Item 5).
23. Fit the plugs (Item 16) to the Top Cap (Item 5).
24. Mark the leg with the part number for the dual damped assembly: GA8-322011-017. Use indelible means and apply the mark to the top cap.
25. Assemble the leg to the aircraft in accordance with the applicable Aircraft Service Manual.

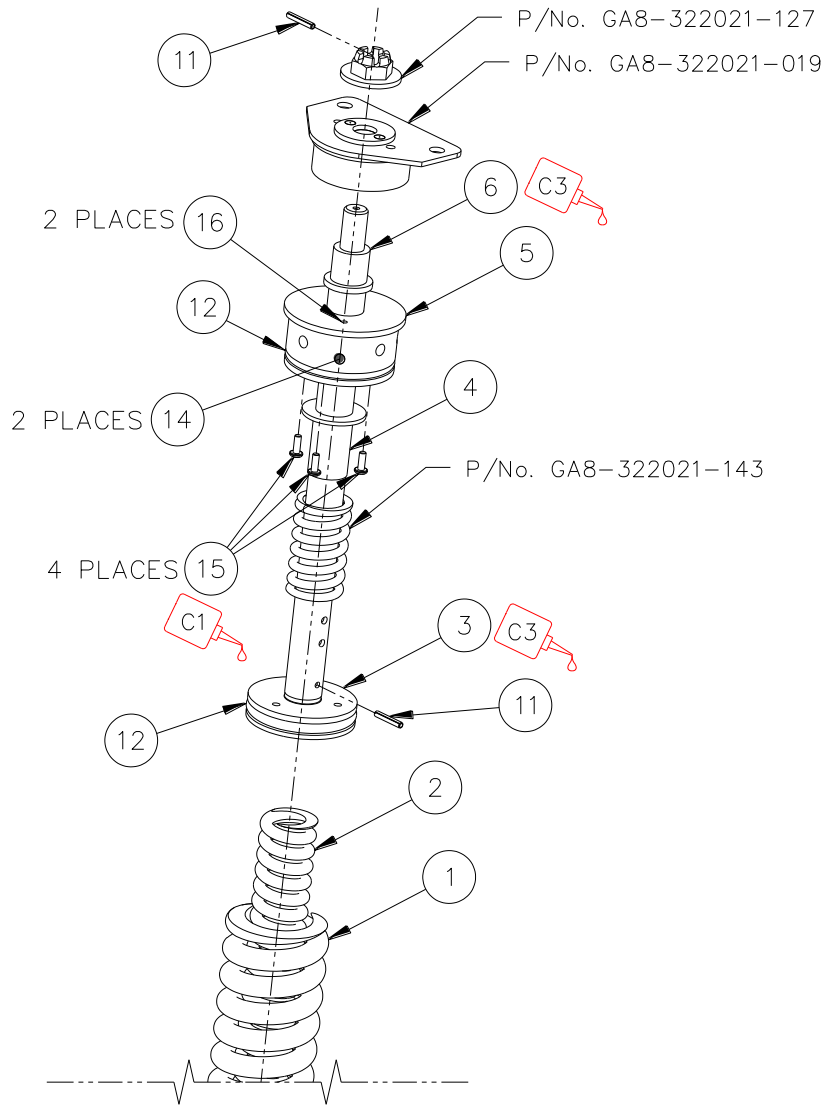

Figure 2: Plunger Assembly Detail

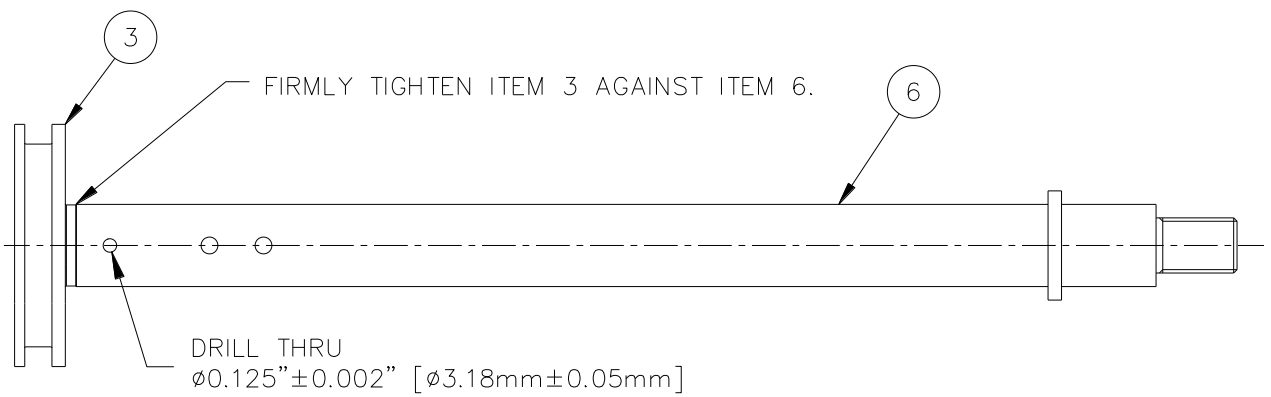

Figure 3: Plunger Installation to Piston Rod Assembly.

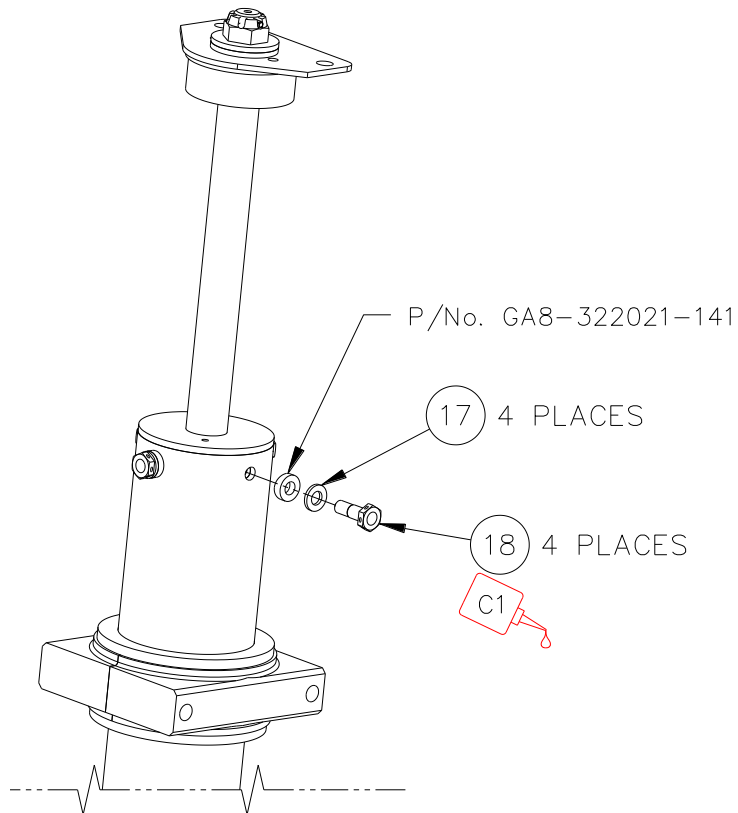

Figure 4: Top Cap Installation

14 Documentation:

Update aircraft logbook to reflect incorporation of this Service Bulletin.

Insert Service Manual Supplement, C05-96-99 into the aircraft's Service Manual.

15 Continuing Airworthiness:

Instructions for Continued Airworthiness are contained in Service Manual Supplement, C05-96-99.

16 Compliance Notice:

Complete the Document Compliance Notice and return to GippsAero by mail, fax or email.

DOCUMENT COMPLIANCE NOTICE



Document:

SB-GA8-2025-220

Issue 2

Aircraft Serial Number: GA8-_____

The following parts of Service Bulletin SB-GA8-2025-220, Issue 2 has been incorporated in the above aircraft (tick as appropriate).

SB-GA8-2025-220 Part A: Dual Damped Nose Leg Installation.

Date of Incorporation: _____

Signed

Print Name: _____

Please post, fax or email this compliance notice to:

GippsAero Technical Services
P.O. Box 881
Morwell Victoria 3840
Australia
Fax.: +61 03 5172 1201
Email: TECHPUBS@gippsaero.com.au